

ETG05201S

English

Frame for an electro-motorised sit-stand workstation



Assembly Manual

P21081.2 E

Read this manual thoroughly and store in a safe place!

Content

1	GENERAL	3
1.1	Local value of the assembly/operating manual	3
1.2	Intended use	3
1.3	Improper use	3
1.4	Laws, directives and standards to be observed	3
1.5	FCC Information for Class B digital device (Power Supply)	3
1.6	Content box	4
2	SAFETY INFORMATION	5
2.1	Symbols/warnings	5
2.2	Symbols used on the workstation frame	5
2.3	Organizational measures	5
2.4	Informal safety measures	5
2.5	Note for those assembling the workstation	5
2.6	Transport and assembly	5
2.7	Safety/protective measures	5
2.8	Dangers due to electrical energy	6
2.9	Use of the workstation frame	6
2.10	Specific dangers	6
2.11	In an emergency	7
2.12	Maintenance and upkeep	7
2.13	Cleaning	7
2.14	Noise generated by the workstation frame	7
2.15	Persistent risks	7
3	ASSEMBLY	8
3.1	Checking the items supplied	8
3.2	Packaging	8
3.3	Tightening torques for screws used	8
3.4	Assembly of the workstation	8
3.4.1	Pre-assembly of the Top and Bottom Crossbar	8
3.4.2	Mounting Bottom Crossbar	9
3.4.3	Mounting Top Crossbar	11
3.4.4	Mounting the Feet	12
3.4.5	Mounting the Top Supports	13
3.4.6	Mounting the Drive Shafts	14
3.4.7	Mounting the Drive Units	16
3.4.8	Adjusting the frame wide	17
3.4.9	Connecting Cables Drive Units	18
3.4.10	Frame test without tabletop	19
3.4.11	Assembly of the tabletop	19
3.4.12	Assembly of the cover of the drive shaft	19
3.4.13	Identification Sticker	19
4	TECHNICAL SPECIFICATIONS	20
5	OPERATION AND INDICATORS	22
5.1	Indicators	22
6	TROUBLESHOOTING	23
7	CUSTOMER SERVICE	24
8	MANUFACTURER	24
9	RECYCLING	24
9.1	Taking the workstation out of active duty	24
9.2	Taking the workstation apart	24
9.3	Recycling	24

1 General

1.1 Local value of the assembly/operating manual

The guiding principle for safe use and trouble-free operation of this workstation frame is knowledge of basic safety information and regulations. This assembly/operating manual contains the most important information needed for assembling and operating the workstation frame safely. This assembly/operating manual, in particular the safety information contained herein, must be observed by any person building the frame and working on the finished surface. More importantly, the rules and regulations applying to accident prevention in the locality in which the workstation frame is to be used must be observed at all times.

1.2 Intended use

The workstation frame must be used only as an electrically height-adjustable workstation for sitting/standing use in offices or other enclosed areas. The frame must be used for this purpose only. The workstation frame may be set up and operated solely in office environments. Do not use the workstation frame in the home. Should it nonetheless be used in the home, a key switch must be used. Please observe the provisions of Section 2, Safety Information. Children may be unaware of the dangers presented by the workstation frame if unsupervised. Any other use than the above shall be deemed improper. The manufacturer can in no way be held liable for damage arising from improper use.

Intended use shall also include:

- Observation of all information from the assembly/operating manual and
- Prohibition of any sort of addition to/conversion of the workstation.

1.3 Improper use

- Never use the workstation frame to lift people or loads.
- Do not exceed the maximum load of the workstation frame (see Section 4, Technical Data).
- Do not use the workstation frame in the home unless using a key switch; alternatively, use it only in offices.

1.4 Laws, directives and standards to be observed.

- Machinery Directive 98/37/EC
- Low Voltage Directive 73/23/EEC
- Electromagnetic Compatibility Directive 89/336/EEC
- EN 12100, parts 1 and 2
- EN 294

1.5 FCC Information for Class B digital device (Power Supply)

This equipment has been tested and found to comply with the limits for a Class B digital device, pursuant to part 15 of the FCC Rules. These limits are designed to provide reasonable protection against harmful interference in a residential installation. This equipment generates, uses and can radiate radio frequency energy and, if not installed and used in accordance with the instructions, may cause harmful interference to radio communications. However, there is no guarantee that interference will not occur in a particular installation. If this equipment does cause harmful interference to radio or television reception, which can be determined by turning the equipment off and on, the user is encouraged to try to correct the interference by one more of the following measures:

- Reorient or relocate the receiving antenna.
- Increase the separation between the equipment and receiver.
- Connect the equipment into an outlet on a circuit different from that to which the receiver is connected.
- Consult the dealer or an experienced radio/TV technician for help.

WARNING **Any changes or modifications not expressly approved by the manufacturer could void the user's authority to operate the equipment.**

1.6 Content box

#	Part name	Qty
01	Leg	2
02	Drive shaft	2
03	Drive shaft extension	1
04	Lower Crossbar	1
05	Top Crossbar	1
06	Foot	2
07	Tabletop support	2
08	Power Supply	1
09	Cover Top Crossbar	2
10	Cover Lower Crossbar	2
11	Power cord	1
12	Nut key 12+14+8	1
13	Nut key 12+14+10	1
14	Allen key 4 and pipe-key	1+1
15	Foot adjusters/leveller	4
16	Cable Keypad	1
17	Drive Unit Master	1
18	Drive Unit Slave	1
19	Link cable drive units	1
20	Keypad up-down	1
21	Mounting hardware kit	div.
22	Cover drive shafts	2

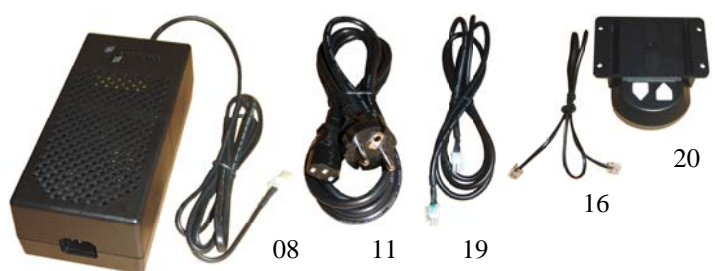
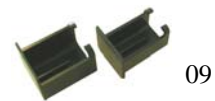

2 Safety Information

2.1 Symbols/warnings

The assembly/operating manual uses the following terms and signs to indicate dangers:



This symbol indicates an immediate threatening situation for any person's life or health. Failure to adhere to such information may have serious consequences for health, or could even result in life-threatening injury or death.



This symbol indicates important information. Failure to adhere to such information could lead to damage to the workstation.

2.2 Symbols used on the workstation frame



Do not place objects or parts of the body under the workstation frame or between the cross members. This could cause serious injury.



Do not exceed the maximum permitted load on the workstation frame. Overloading could lead to breakage and serious injury as a consequence.

2.3 Organizational measures

- The workstation frame can best be assembled by two people. Turning the frame, once the work surface has been fitted, is a task in particular which requires two people!

2.4 Informal safety measures

- Keep the assembly/operating manual in the place where the workstation frame is used at all times.
- Make sure that all safety information on the table (see Section 2.2, Symbols used on the workstation frame, page 5) is legible, replacing the same if necessary.

2.5 Note for those assembling the workstation

- The workstation must be assembled/worked on by persons over the age of 16.
- The persons referred to above must have read and understood the assembly/operating manual.

2.6 Transport and assembly

- The workstation frame must only be moved when it is disconnected from mains electricity (i.e. when the plug has been removed from the socket).
- The workstation frame must be moved by two persons only, and in such cases must be retracted.
- Do not drag or pull the workstation frame over the floor.
- Assemble the workstation frame with the supplied tools only. They are the only tools which ensure that the screws can be tightened to the correct torque.

2.7 Safety/protective measures

- Replace the drives if the circuit breaker in the drives fails. Faulty circuit breakers will not switch off the drive in the top/bottom setting. In such cases, the workstation frame has been taken to the mechanical stop and can no longer be raised/lowered.

2.8 Dangers due to electrical energy

- Do not connect the workstation frame to the mains electricity until the assembly is complete.
- Check the electrical equipment in the workstation frame regularly to see that it complies with national legislation (e.g. *Unfallverhütungsvorschriften* in Germany).
- Do not use any wires with damaged insulation. This will increase the risk of electric shock. If any wiring is found to be damaged, replace it immediately with new wiring.
- Do not position the power feed near any sources of heat. The persistent heat could damage the wire. This could easily lead to a fire or a short circuit.
- Disconnect the workstation frame from the mains electricity if the frame is not in use for an extended period.

2.9 Use of the workstation frame

- Do not use the workstation frame without a key switch except in an office environment.
- Do not use the workstation frame in the home without a key switch or with a faulty key switch.
- Do not allow children to use the workstation frame unsupervised. Children may be unaware of the dangers presented by the workstation frame. They would be in serious danger of injuring themselves, possibly even with fatal consequences. After each adjustment, lock the drive using the key switch (see Section 5 Operation and Indicators). Further adjustment must then be impossible as a safeguard against use by children. Keep the key in a secure place, out of the reach of children.
- The workstation frame must only be used in appropriate areas (see Section 4 Technical Data).
- Do not use the workstation frame on an uneven surface. In such conditions it will not be steady.
- Be aware that the workstation frame has a 10% time lag. This means that no further adjustment in height is possible for a further nine (9) minutes.
- Never exceed the maximum load on the workstation frame (see Section 4 Technical Data).

2.10 Specific dangers

- When adjusting the height of the frame there is danger of injury. Make sure that there is no-one else in the immediate surroundings of the frame.
- When assembling the workstation frame, make sure there is ample space to avoid collisions (i.e. inclination of roof, fixed objects, filing cabinets, waste-paper bins etc.) in all imaginable directions.
- Make sure there is ample space to avoid collisions if there are objects on the work surface such as computers or computer peripherals.
- Make sure there is clearance of at least 25 mm from all other furniture, all around the workstation frame.

2.11 In an emergency

- Leave the immediate surroundings of the workstation frame at once if it starts to move spontaneously. Under no circumstances attempt to operate the workstation frame. Have the workstation frame repaired by specialists. Refrain from using the workstation frame until it has been successfully repaired.
- Stop using the workstation frame at once if you notice anything unusual (strange sounds, smoke, etc.).
- Have the workstation frame repaired by specialists. Refrain from using the workstation frame until it has been successfully repaired.
- Stop using the workstation frame at once if its safety features (e.g. key switch, end switch) fail to work as they should.

2.12 Maintenance and upkeep

- The workstation frame and its components are low-maintenance items and need no special regular maintenance.
- Do not perform any repairs on the work surface or other components yourself.
- Do not alter the construction of the work surface or its frame.
- Do not exceed the maximum time lag of the workstation frame (see Section 2.9 Use of the workstation frame).
- Any faulty components removed must be replaced with new, original components from the manufacturer. Use only original replacement parts made by the manufacturer. Have any such work carried out by a specialist, making reference to this Assembly/operating manual.

2.13 Cleaning

- Dust the workstation frame once a week with a dry cloth.
- Clean the workstation frame with a damp cloth and a weak solution of cleaner once a fortnight.

2.14 Noise generated by the workstation frame

- The noise generated by this workstation frame is less than 50 dB(A)

2.15 Persistent risks

This workstation frame has been built to the state of the art and to recognized safety regulations. Nonetheless, its use may constitute a risk to the health and safety of users or third parties, damage to the workstation frame or to other items. The workstation frame must be used only:

- for the purpose for which it was intended.
- if it is completely safe so to do.

3 Assembly



Before attempting assembly, read the safety information in Section 2.

3.1 Checking the items supplied

- Carefully open the cardboard packaging.
- In doing so, do not use any long knife blades. They may damage the components inside.
- Check the parts supplied against the list in Section 1.4 Items supplied.
- Check the contents for visible transit damage, paying particular attention to the electrical wiring. In the event of any damage or incorrect components, contact customer services (see Section 7).
- Do not attempt to assemble the workstation frame if there is any damage or if there are any incorrect components.

3.2 Packaging

- Remove the packaging. Treat as household waste/paper.
- Observe national legislation.

3.3 Tightening torques for screws used

- Assemble the workstation frame with the tools supplied only.

3.4 Assembly of the workstation

3.4.1 Pre-assembly of the Top and Bottom Crossbar

Assemble the following components:

#	Part name	Qty
04	Bottom Crossbar	1
05	Top Crossbar	1
14	Allen key	1
21	Socket screw M6x6	4

Indicative:	
Frame set-up	Wide/size tabletop
1,18 m	120 cm
1,3 m	140 cm
1,5 m	160 cm
1,7 m	180 cm



- Assemble the 4 socket screws (2 per Crossbar) in the tapped holes.
- ☞ Do not yet tighten the socket screws!
- Tighten the socket screws only after assembling the components in step 3.4.8 Adjustment of the wide of the frame, page 17.

3.4.2 Mounting Bottom Crossbar

Assemble the following components:

#	Part name	Qty
01	Leg	2
04	Pre assembled Bottom Crossbar	1
10	Cover Bottom Crossbar	2
13	Nut key 10	1
14	Allen key	1
21	Flange nut M6	4
21	Socket screw M6x25	2
21	Socket screw M6x12	2

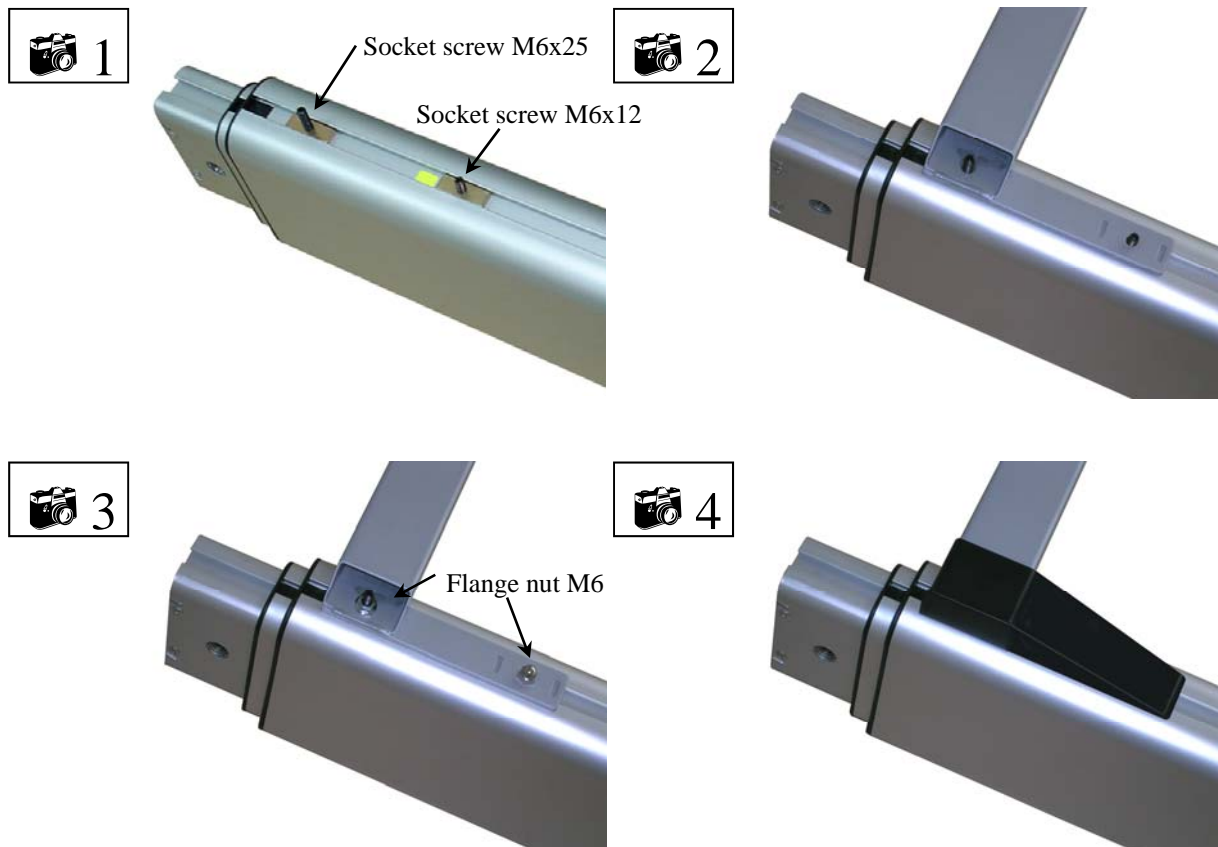

Photo 1

- Place the legs flat on the floor, parallel to each other.
- ☞ Be aware that both slide nuts point upwards.
- Fasten the socket screws in the slide nuts. The long socket screw in the upper slide nut and the smaller socket screw in the lower (fixed) slide nut.
- Gently tighten the socket screws with the 4 mm Allen key.

Photo 2

- Place the pre-assembled bottom crossbar over the socket screws.

Photo 3

- Place the 4 flange nuts on the socket screws.
- Tighten the 4 flange nuts with the nut key 10.

Photo 4

- ☞ Be aware that the covers are different of size. Do not use too much force while placing these covers, they could break or damage.
- Place the covers over both ends of the bottom crossbar.

3.4.3 Mounting Top Crossbar

Assemble the following components:

#	Part name	Qty
01	Pre assembled Leg	2
05	Pre assembled Top Crossbar	1
09	Cover Top Crossbar	2
13	Nut key 10 or pipe key 10	1
14	Allen key	1
21	Flange nut M6	2
21	Socket screw M6x25	2
21	Slide nut	2

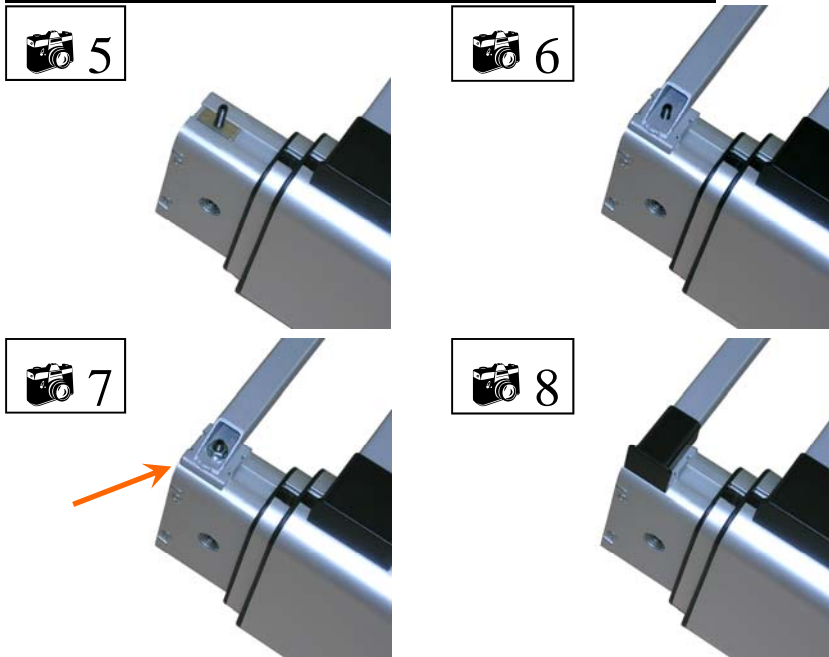

Photo 5

- Place a slide nut in the slit at the top of each leg.
- Place a socket screw in each of the slide nuts.
- Gently tighten the socket screws with the 4 mm Allen key.

Photo 6

- Place the pre-assembled top crossbar over the socket screws.
- ☞ Be aware that the top crossbar is flush with the top of the legs.

Photo 7

- Place the 2 flange nuts on the socket screws.
- Tighten the 2 flange nuts with the pipe key 10.

Photo 8

- ☞ Be aware that the covers are different of size. Do not use too much force while placing these covers, they could break or damage.
- Place the covers over both ends of the top crossbar.

3.4.4 Mounting the Feet

Assemble the following components:

#	Part name	Qty
06	Foot	2
13	Nut key 10 or pipe key 10	1
15	Foot adjuster	4
21	Bolt M6x25	8
21	Washer M6	8



Photo 9

- Place 2 foot adjusters on the bottom of each foot.

Photo 10 & 11

- Turn the pre-assembled legs and crossbars up-side-down (with 2 persons). The crossbars are now closest to the floor.



Secure the pre-assembled legs against falling over.

- Position the foot, like photo 11, in relation to the crossbars
- Connect each foot to a leg with 4 bolts and 4 washers.
- Tighten the 8 bolts with the pipe key 10.

Photo 11

- Turn the frame back on its foot (with 2 persons).

3.4.5 Mounting the Top Supports

Assemble the following components:

#	Part name	Qty
07	Top Support	2
12	Nut key 8	1
21	Bolt M5x25	8
21	Washer M5	8







Photo 12 & 13

- Position the top support, like photo 13, in relation to the crossbars
- Connect each top support to a leg with 4 bolts and 4 washers.
- Tighten the 8 bolts with the nut key 8.

3.4.6 Mounting Drive Shafts

Assemble the following components:

#	Part name	Qty
02	Drive Shaft	2
03	Drive Shaft Extension	1
12	Nut key 14	1
17	Drive Unit Master	1
18	Drive Unit Slave	1

-  Be aware that both legs are completely in the lowest position.
-  Be aware that the drive units have not been connected to a power source and not been used.
-  Be aware that all components are originally packed.
-  Be aware that the 2 drive units are different (Master & Slave). Place the master drive unit at the side where the up-down switch will be placed.

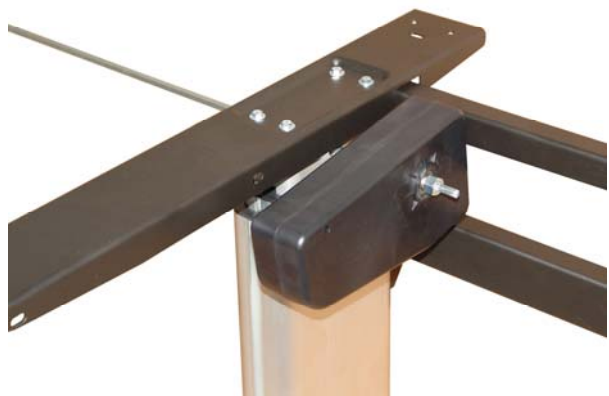

Photo 14

- Slide the 2 drive shafts through the hexagon holes in the 2 legs.
- Slide both shafts in until they stick ± 15 cm inside the frame.

Photo 15

- Slide the Master drive unit over the, to the inside of the frame sticking, drive shaft. At the side where the up-down switch needs to be placed.

Photo 16

- Slide the Slave drive unit over the, to the inside of the frame sticking, drive shaft. At the opposite side of the Master drive unit.

Photo 17

- Slide the drive shaft Extension over both, to the inside of the frame sticking, drive shafts.

Photo 18

- Slide both drive shafts inward, until they are flush with the surface (of the outside) of the leg.



3.4.7 Mounting Drive Units

Assemble the following components:

#	Part name	Qty
12	Nut key 14	1
21	Bolt M6x80	2
21	Washer M6	2
21	Flange nut M6	4
21	Plastic spacer	2

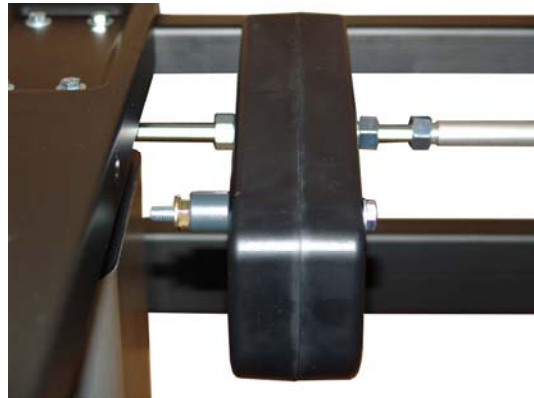
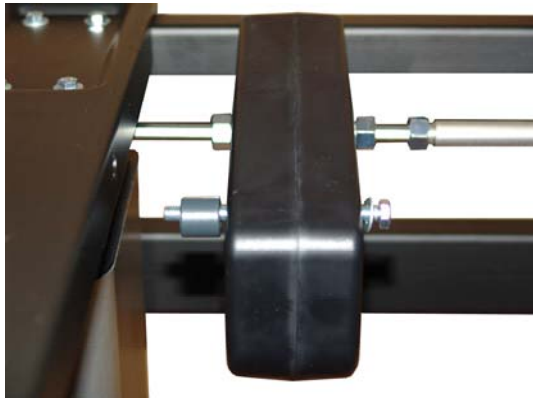

Photo 19

- Slide the long bolt (M6x80mm) with a washer through the specific hole in the drive unit.
- Slide the plastic spacer over the already placed bolt (between the drive unit and the top support).

Photo 20

- Screw a flange nut, as showed on the photo, over the bolt.

Photo 21

- Slide the bolt through the specific hole in the top support.
- Screw a flange nut, as showed on the photo, from the inside of the top support over the bolt.
- Tighten this flange nut.

Photo 22

- ☞ Be aware of that the drive unit is parallel in relation to the top support.

3.4.8 Adjusting the frame wide

- Pull the frame outward to the required wide (see chapter 3.4.1 Pre-assembly of the Top and Bottom Crossbar)
- Tighten the socket screws in the top and bottom crossbar only now.

Photo 23

- Tighten the 6 pinching nuts on the drive shaft extension and on both drive units with the nut key 14.



3.4.9 Connecting Cables Drive Units

Assemble the following components:

#	Part name	Qty
08	Power Supply	1
11	Power Cord	1
16	Cable Keypad	1
19	Link Cable Drive Units	1
20	Keypad	1

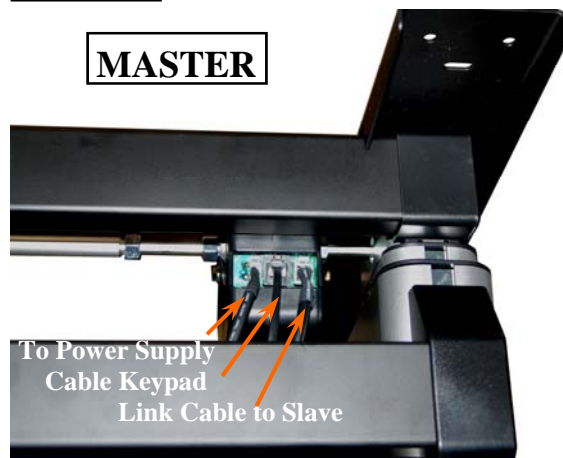

Photo 24

- Connect the Link cable with the connector in the Slave drive unit.

Photo 25

- Connect the other end of the Link cable to the correct connector in the Master drive unit.
- Connect the Keypad Cable to the Keypad and the correct connector of the Master drive unit.
- Connect the Power supply Cable to the correct connector of the Master drive unit.



Make sure that the course of the cables is always unobstructed! Tighten the cables to the top crossbar or top support with tape or cable binders (not included).

Photo 26

- Connect the power cord to the power supply and stick the plug in to the electricity socket (115-230 V~, 50-60Hz).

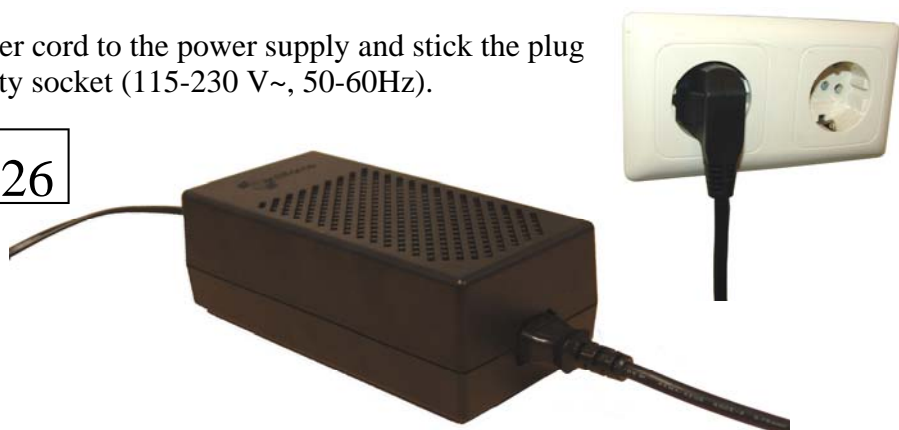

3.4.10 Frame test without tabletop

Photo 27

- Press “UP” button, the frame goes up.
- Release the button, the frame stops.
- Press “DOWN” button, the frame goes down.
- Release the button, the frame stops.



DOWN UP



Make sure that the workstation frame can move correctly and freely at all times. Should this no longer be the case, disconnect it from the mains electricity and report it to customer services (see Section 7).

3.4.11 Assembly of the tabletop

See separate manual of the tabletop.

3.4.12 Assembly of the cover of the drive shaft

See separate manual of the tabletop.

3.4.13 Identification Sticker

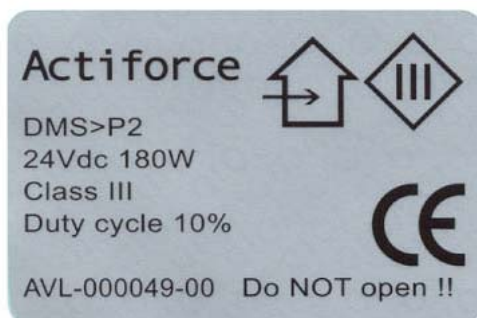

4 Technical Specifications

Frame for Sit-Stand Workstation

Assembly Manual version	P21081.2 E (06-2005)
Year of construction	2005
Production country	Malaysia
System	2-step, external drive
Material	Aluminium, steel and plastic
Stroke (max.)	650 mm
Frame load (max.)	100 kg
Frame weight	± 25 kg
Speed 0 kg frame load	± 42 mm/s
Speed 80 kg frame load	± 33 mm/s
Input power	100 - 240 V~, 1,5 A, 50/60 Hz
Duty cycle	10 % (1 Minute on / 9 Minutes off)
Life span	3.500 Cycles (NEN 2441-2002)
	10.000 Cycles (average use)
Noise level	< 50 dB(A)
Environmental temperature Use	15 - 30°C
Environmental temperature Storing	10 - 50°C
Humidity Use	<85%
Humidity Storing	<50%
Maximum Storing time	-
Indoor use only!!!	

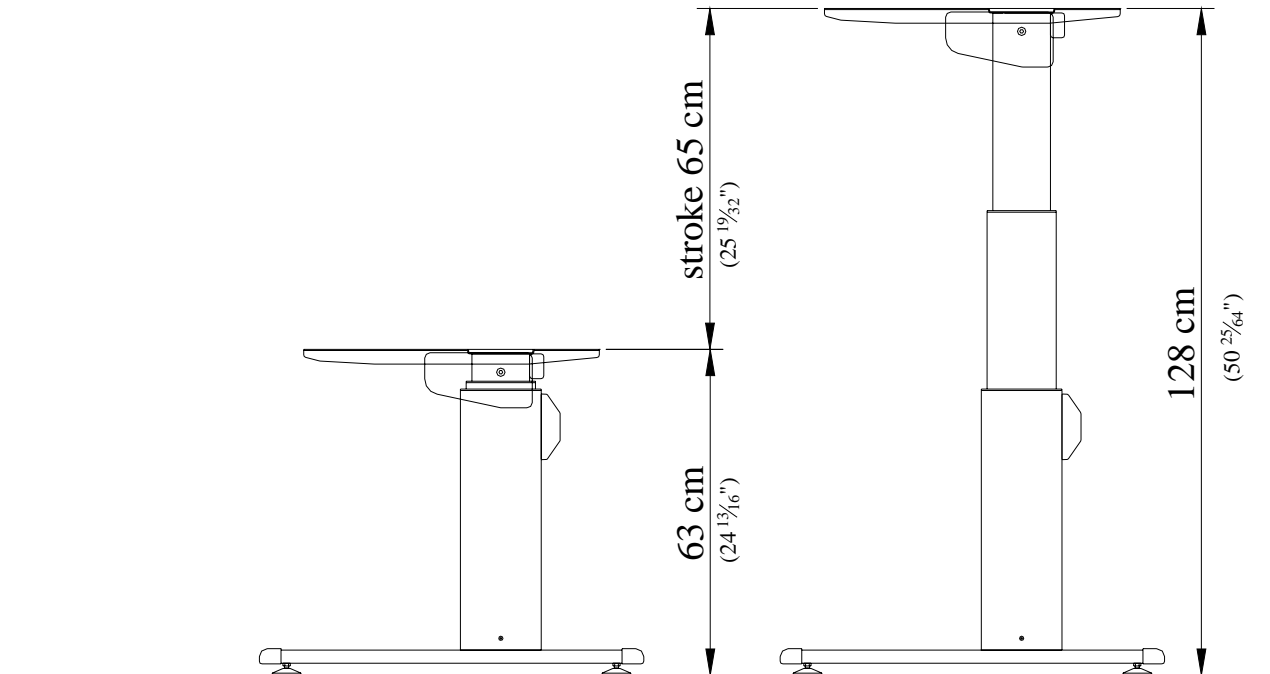
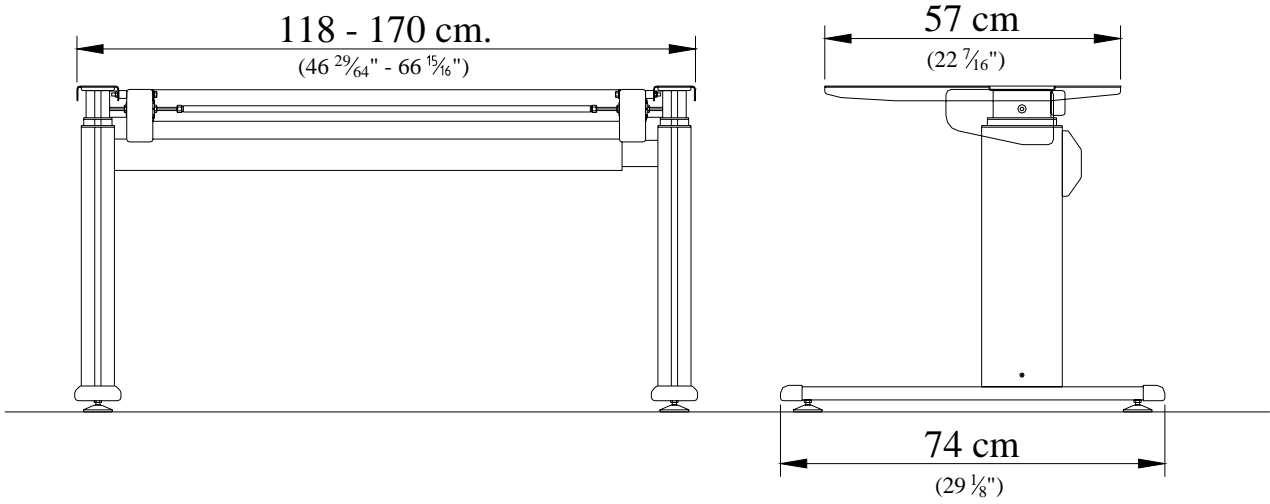

Minimum Frame Height	63 cm	(24 13/16")
Maximum Frame Height	128 cm	(50 25/64")
Maximum Stroke	65 cm	(25 19/32")
Frame Width	118 - 170 cm	(46 29/64"- 66 15/16")
Frame Depth	74 cm	(29 1/8")
Minimum Tabletop Depth	57 cm	(22 7/16")
Maximum Frame Load	80 kg	(177 lb)
Speed 0 kg (0 lb) load	±42 mm/s	(1 21/32 inch/s)
Speed 80 kg (177 lb) load	±33 mm/s	(1 19/64 inch/s)

5 Operation and Indicators

	<p>Observe the provisions of Section 2 Safety Information on page 5, in particular:</p> <p>Do not leave children unsupervised with the workstation frame. Children may be unaware of the dangers presented by the workstation frame. They would be in serious danger of injuring themselves, possibly even with fatal consequences. After each adjustment, lock the drive using the key switch. Further adjustment must then be impossible as a safeguard against use by children. Keep the key in a secure place, out of the reach of children.</p> <p>Do not exceed the maximum time lag of the workstation frame.</p> <p>Make sure there is ample space to avoid collisions if there are objects on the work surface such as computers or computer peripherals.</p>
---	--

5.1 Indicators

	<p>Leave the immediate surroundings of the workstation frame at once if it starts to move spontaneously. Under no circumstances attempt to operate the workstation frame. Have the workstation frame repaired by specialists. Refrain from using the workstation frame until it has been successfully repaired.</p> <p>Stop using the workstation frame at once if you notice anything unusual (strange sounds, smoke, etc.).</p> <p>Have the workstation frame repaired by specialists. Refrain from using the workstation frame until it has been successfully repaired.</p> <p>Stop using the workstation frame at once if its safety features (e.g. key switch, end switch) fail to work as they should.</p>
---	--

6 Troubleshooting

Problem	Possible cause	Solution
Frame is not moving	Cable or connector problem	Check all connectors
Frame is not moving	Overload	Pull out the power plug and wait 10 minutes. Put the plug back in and try again.

When the problem is not in the list above, please contact the customer service.

7 Customer Service

When contacting the customer service please

Retailer:

8 Manufacturer

Actiforce International BV

PO Box 224

3750 GE Bunschoten

The Netherlands

www.actiforce.nl

9 Recycling

9.1 Taking the workstation out of active duty

- Pull the power plug out of the electricity socket.

9.2 Taking the workstation apart

- In case of de-assembling please follow the manual backwards or contact customer service.

9.3 Recycling

- Please split all parts to their type of material. Keep notice of National restrictions!